



Oklahoma Christian School

4680 E 2nd Street, Edmond, OK 73034

(405) 341-2265

Summer Assignment 2022 **for Intermediate Algebra** **Students**

Dear Intermediate Algebra Student,

Welcome to Intermediate Algebra, where you will expand on previous topics of Algebra I such as factoring, quadratics, exponents, radicals, solving equations, and graphing. This class will push you to master fundamental practices of Algebra while also expanding on your depth of knowledge in these topics.

As a student in Intermediate Algebra, **you are expected to complete the summer math packet with work shown prior to the first day of fall semester of 2022.** The packet can be found on the OCS website under High School > Documents and Forms > Summer 2022 Math Prep - Intermediate Algebra

Please know that you are responsible for bringing the completed packet(with work shown) to class.

You may use any of the additional resources that are provided below to supplement or relearn topics. You may ask clarification questions before a **review test**. Please make sure to read through every topic thoroughly and use the recommended additional resources for extra practice.

Thank you so much, and I look forward to seeing you on the first day!

Video Help:

- Krista King Math
- Khan academy
- YouTube

Worksheet/practice problems for extra practice:

www.ixl.com/math

www.kutasoftware.com

Intermediate Algebra Summer Math

1. Use a number line to order the numbers: $\frac{3}{5}$, $\frac{2}{3}$, $\frac{5}{3}$



2. Write the numbers in *increasing* order.

$$\frac{5}{3}, -2, 0, -\frac{7}{2}, \frac{3}{5}, \frac{4}{3}, -1$$

3. Convert 10 yards to inches.
4. A string is 0.5 meters long. What is its length in centimeters?
5. You buy 3 pounds of hamburger at \$3.25 per pound. What is the total cost of the hamburger?
6. How long does it take to travel 150 miles at an average speed of 60 miles per hour?
7. Evaluate the power. $(-3)^5$
8. Evaluate $2s + 4t$ for $s = 3$ and $t = -2$.
9. Evaluate $\frac{1}{2}(7 + 5y) \div 3x$ when $x = \frac{1}{6}$ and $y = 3$.
10. Evaluate $2a^3 + 2a^2$ when $a = -2$.

11. Evaluate $\frac{42-z}{-2z+4}$ when $z = -2$.

12. Simplify the expression.
 $6(d + 1) - 2(d + 1)$

13. Simplify the expression.
 $19h - 17h$

14. You and five friends go to a movie. The tickets cost \$4.50 each. You each buy a drink for \$2.25 and a box of popcorn for \$3.25. Write an expression that represents the total amount of money spent. Then evaluate the expression.

15. Solve. $8x = 88$

16. Solve. $\frac{c}{8} = 27$

17. Solve. $9 - 3t = 12$

18. Use an equation to model the sentence.
How many raisins are left in a jar of 29 raisins after you have eaten some?

19. Solve the equation. Check your solution.
 $2q - 9 = -39$

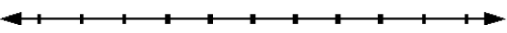
20. Jeff earns \$4.00 an hour baby-sitting. He is saving to buy a pair of in-line skates that costs \$116.00. If Jeff already has \$60.00 saved, how many hours must he baby-sit in order to buy the skates?
21. Solve the equation. $-3x + 5 = -7x - 4$
22. Solve the equation. $5(3 - 4x) = 7 - (4 - x)$
23. Solve the equation. $4(2x - 3) = 6 - (3 - 2x)$
24. Solve the equation.
 $a + 3 = -4a - 6$
25. Solve the equation.
 $3.1g - 0.9 = 0.8g + 19.8$
26. Solve the equation.
 $7x - 29 - 21x = 3 - (12 + 2x)$
27. Solve the equation.
 $0 = \frac{3}{11}h - 21$
28. Solve the equation.
 $0 = \frac{4}{15}h - 16$
29. Solve for F :
 $C = \frac{5}{9}(F - 32)$
30. Solve for s :
 $-5 = t + 4s$
31. Solve for d :
 $-4c - d = c + 6d$
32. Hannah pays \$39 per month for her cellular phone, which includes 1 hour of use. After the first hour, she pays 20¢ per minute. How much will her monthly bill be if she uses her phone 2.5 hours?
33. A rectangle is 5 feet longer than it is wide. The perimeter of the rectangle is 34 feet. What is the length of the rectangle?
34. Connie takes at least 37 seconds to recite a poem. Write and graph an inequality to describe this interval.
- 
35. The cost of a box of stationery ranges from \$1.75 to \$2.45. Write and graph an inequality to describe this statement.
- 

36. Solve the inequality. Then graph your solution.
 $-9v - 10 \leq 7v + 6$



37. Solve the inequality. Then graph your solution.
 $2x + 5 \geq 2 - (x - 9)$



38. Solve the compound inequality.
 $x - 3 \leq 5$ or $x + 4 \geq 14$

39. Solve the compound inequality.
 $-6 < -3t + 6 < 6$

40. Solve the absolute value equation.
 $|x + 7| = 2$

41. Solve the absolute value equation.
 $8|x + 2| = 56$

42. Solve the absolute value equation.
 $|6a + 2| = 6$

43. Solve the absolute value equation.
 $|3x - 7| + 7 = 4$

44. Solve the absolute value inequality.
 $|2x - 4| - 1 > 0$

45. Solve the absolute value inequality.
 $|b - 5| \leq 2$

46. Find the slope of the line passing through the points $(-1, 1)$ and $(7, -6)$.

47. Find the slope of the line.

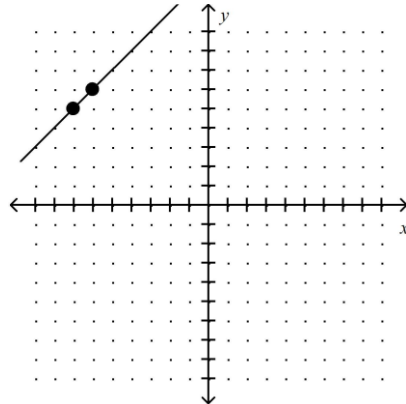

48. Tell whether **Line 1** and **Line 2** are *parallel*, *perpendicular*, or *neither*.

Line 1 passes through $(-5, -8)$ and $(-8, -4)$

Line 2 passes through $(-2, -2)$ and $(-5, 2)$

49. Line 1 contains $(2, -4)$ and $(0, 2)$. Line 2 contains $(-4, 5)$ and $(-1, 6)$. Are the lines parallel, perpendicular, or neither?

50. Graph $y = \frac{2}{3}x + 2$

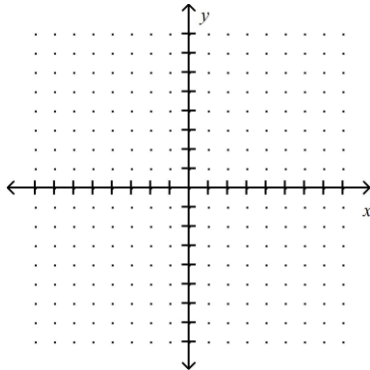

51. Graph the equation.
 $4x + 6y = 24$

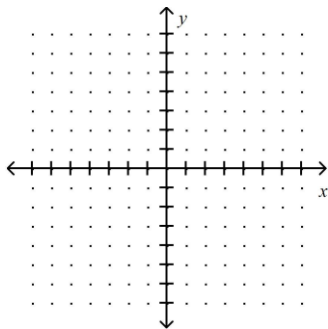

52. Write an equation of a line in slope-intercept form that has a slope -7 and y -intercept 5 .

53. Write the equation of the line, in slope-intercept form, that passes through the point $(-6, -5)$ and has slope 2 . (Hint: Point-Slope Form)

54. Write the equation of the line, in slope-intercept form, that passes through the point $(3, 1)$ and has slope 3 . (Hint: Point-Slope Form)

55. Write the slope-intercept equation of the line that passes through the point $(3, -3)$ and is parallel to the line $y = -3x + 1$? (Hint: Point-Slope Form)

56. Write the slope-intercept equation of the line that passes through the point $(1, 1)$ and is parallel to the line $y = -6x - 4$? (Hint: Point-Slope Form)

57. Write the equation of the line that is parallel to the given line and passes through the given point. Express your answer in slope-intercept form.
 $y = -5x + 2$; $(0, -2)$

58. Write the equation of the line that is parallel to the given line and passes through the given point. Express your answer in slope-intercept form.
 $y = 6x - 5$; $(0, 1)$

59. Write an equation of the line that is perpendicular to the given line and passes through the given point. Express your answer in slope-intercept form.
 $y = -5x + 5$; $(0, 6)$

60. Write an equation of the line that is perpendicular to the given line and passes through the given point. Express your answer in slope-intercept form.
 $y = 3x - 4$; $(0, 5)$

61. Find the slope-intercept equation of the line passing through the points $(-3, -5)$ and $(6, -2)$.

62. Find the slope-intercept equation of the line passing through the points $(5, -8)$ and $(-2, -6)$.

63. Graph the inequality in a coordinate plane. $\frac{7}{3}x > 7$

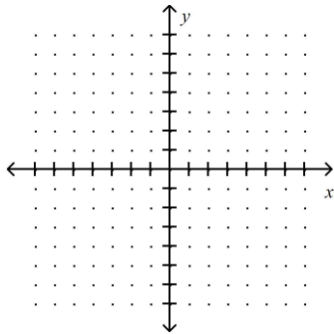

64. Graph the inequality in a coordinate plane. $\frac{2}{3}y > -\frac{4}{3}$

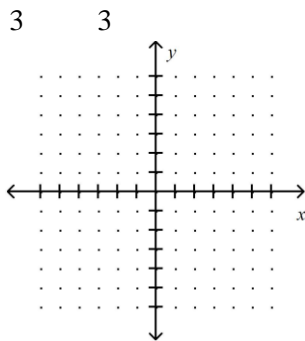

65. Graph the inequality in a coordinate plane.

$$-y \leq 3x - 5$$

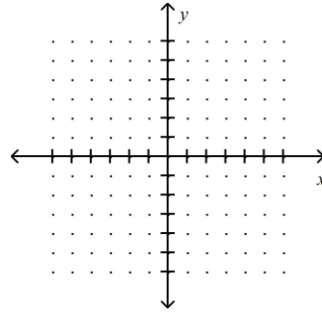

66. Graph the inequality in a coordinate plane.

$$5x - 6y < -30$$

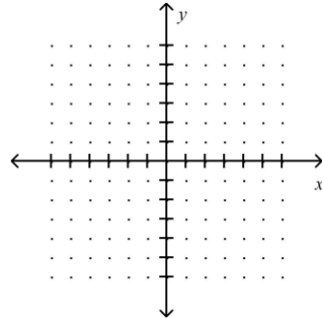

67. Simplify the expression. Give your answer in exponential form.

$$6^9 \times 6^1$$

68. Simplify the expression. Give your answer in

exponential form.

$$\left[\frac{2}{p} \right]^4 \left[\frac{q}{v} \right]^4$$

69. Simplify the expression. Give your answer in exponential form.

$$\left[\frac{u^6}{5} \right]^6 \left[\frac{v}{v} \right]^6$$

70. Simplify the expression. Give your answer in exponential form.

$$2d^3 \cdot d$$

71. Simplify the expression. Give your answer in exponential form.

$$\frac{-2x^{-3}x^2}{x}$$

72. Simplify $(x^5)^{-7}x^3$

73. Simplify $\frac{b^{10}p^{16}}{(bp)^4}$

$$\frac{3x^8}{x^4}$$

74. Simplify $\frac{x^6y^6}{x^4y^4}$

75. Simplify $\frac{-5x^0y^{-5}}{z^{-5}}$.

76. Simplify $(-2)^0$.

77. Simplify. All variables represent nonnegative numbers.

$$\frac{a^6b^1}{2^2} \cdot \sqrt[6]{b^9}$$

78. Add or subtract.

$$-m^2 + 2m^3 - 7m^2 + 19m^3$$

79. Multiply.

$$(z-2)(z-1)$$

80. Multiply.

$$(8x + 5y)^2$$

81. Multiply. $(-5t - 4v)(-3t - 3v)$

82. Multiply.

$$(m-8)^2$$

83. Multiply. $(4l + 5)(4l - 5)$

84. Multiply.

$$(f+10)(f-10)$$

85. Divide.

$$14.884 \div 0$$

86. Graph the point $(1, -4)$.

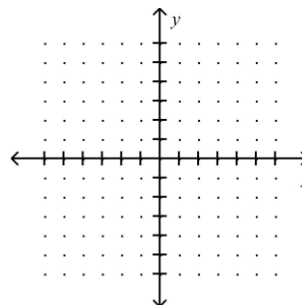

87. Graph the point $(1, -1)$.

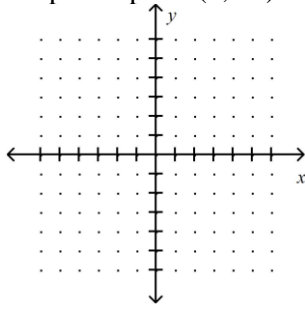

88. Name the quadrant where the point $(3, 1)$ is located.

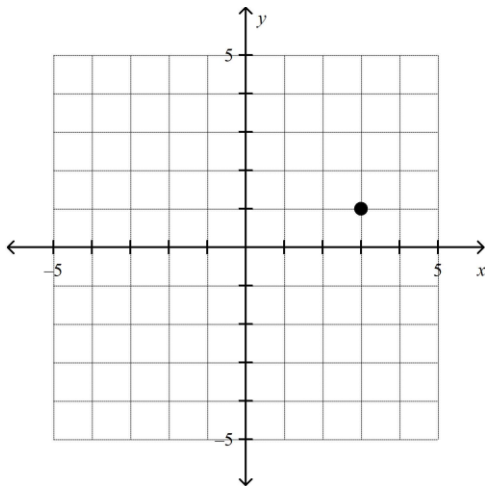

89. Create a table of ordered pairs for the function $y = 2x^2 - 2$ using the values $x = -2, -1, 0, 1,$ and 2 . Graph the ordered pairs and describe the shape of the graph.

90. Solve $-2m + 6 + 10m = -8 + 8m + 24$. Tell whether the equation has infinitely many solutions or no solutions.

91. Solve $-5y + 6 + 6y = -4 + y + 10$. Tell whether the equation has infinitely many solutions or no solutions.

92. The formula for the resistance of a conductor with voltage V and current I is $r = \frac{V}{I}$. Solve for V .

93. Solve $4x - z = y$ for x .

94. Find the x - and y -intercepts.

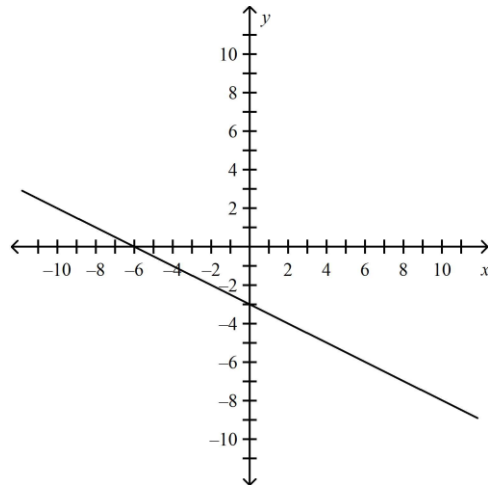

95. Use intercepts to graph the line described by the equation $-3x + 3y = -3$.

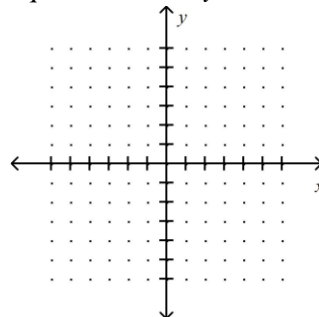

Name: _____

ID: A

96. Add.

$$(2e^5 - e^2) + (e^5 + 7e^2 - 4)$$

97. Multiply.

$$\left(\frac{1}{11}p^3y^2\right)(y^4z^4)(44p^3z^4)$$

98. Subtract.

$$(6b^5 - b^2) - (b^5 + 8b^2 - 4)$$

99. Multiply. $-2r^3 \begin{matrix} \square \\ \square \\ \square \end{matrix} 3r^2 - 4r - 3 \begin{matrix} \square \\ \square \end{matrix}$

100. Multiply.

$$3c^6d^5 \begin{matrix} \square \\ \square \\ \square \end{matrix} - 4c^4d^2 + 5d^2 \begin{matrix} \square \\ \square \\ \square \end{matrix}$$